

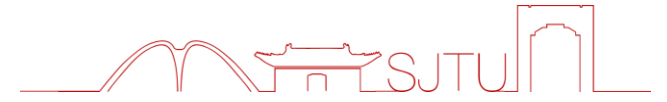

上海交通大学  
SHANGHAI JIAO TONG UNIVERSITY



# 高温工业热泵现状、技术发展趋势和案例分享

吴迪

上海诺通新能源科技有限公司/上海交通大学

2023年7月25日

饮水思源·爱国荣校



1

**背景**

2

**工业热泵现状与总结**

3

**工业热泵技术发展路线**

4

**典型研究案例**

5

**总结展望**



## 工业供热消耗大量能源

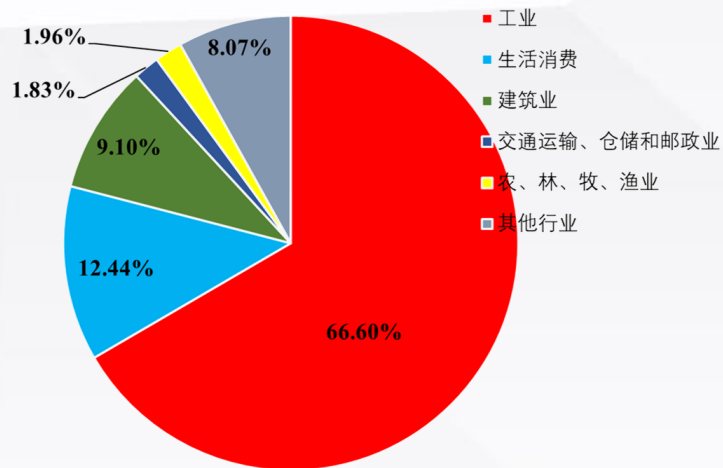

工业能耗占据了我国全社会总能耗的**60%以上**，其中**50%**用于工业生产过程供热

## 工业供热碳排放高、污染重



超过**65%**的热能是通过化石燃料燃烧提供的，仅工业锅炉一年可排放超过**1.3亿吨CO<sub>2</sub>**，**33%**的烟尘和**27%**的SO<sub>2</sub>

## 工业锅炉替代品各有弊端

工业供热装置	存在的缺点与问题
燃料锅炉 天然气/石油/生物质	燃料价格高，不环保，污染严重
太阳能锅炉	设备成本高，受天气限制，无法稳定供热
电热锅炉	耗电量大，电力运行成本过高

小型燃煤锅炉被禁用，但现有工业锅炉替代品还存在一些问题

### 工业供热设备的节能环保与我国的能源利用与生态保护息息相关!





## ► 热泵可减少工业供热碳排放

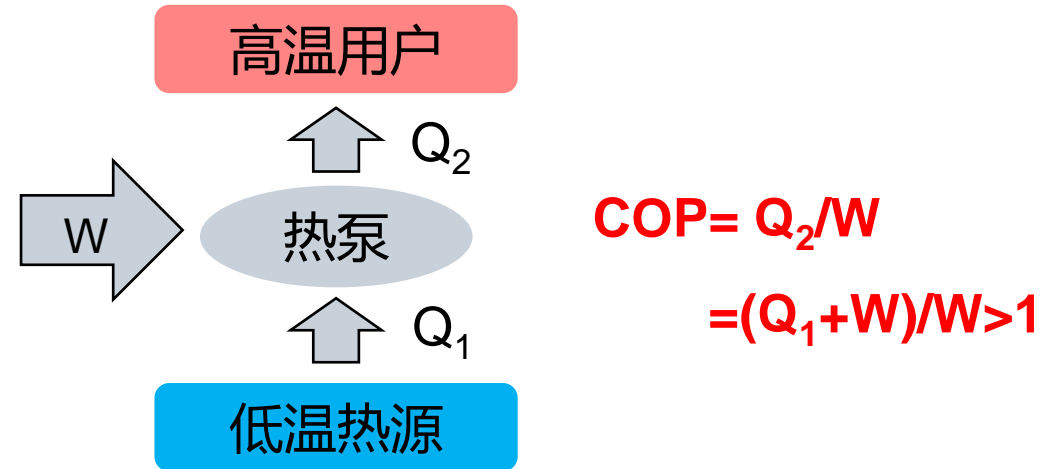
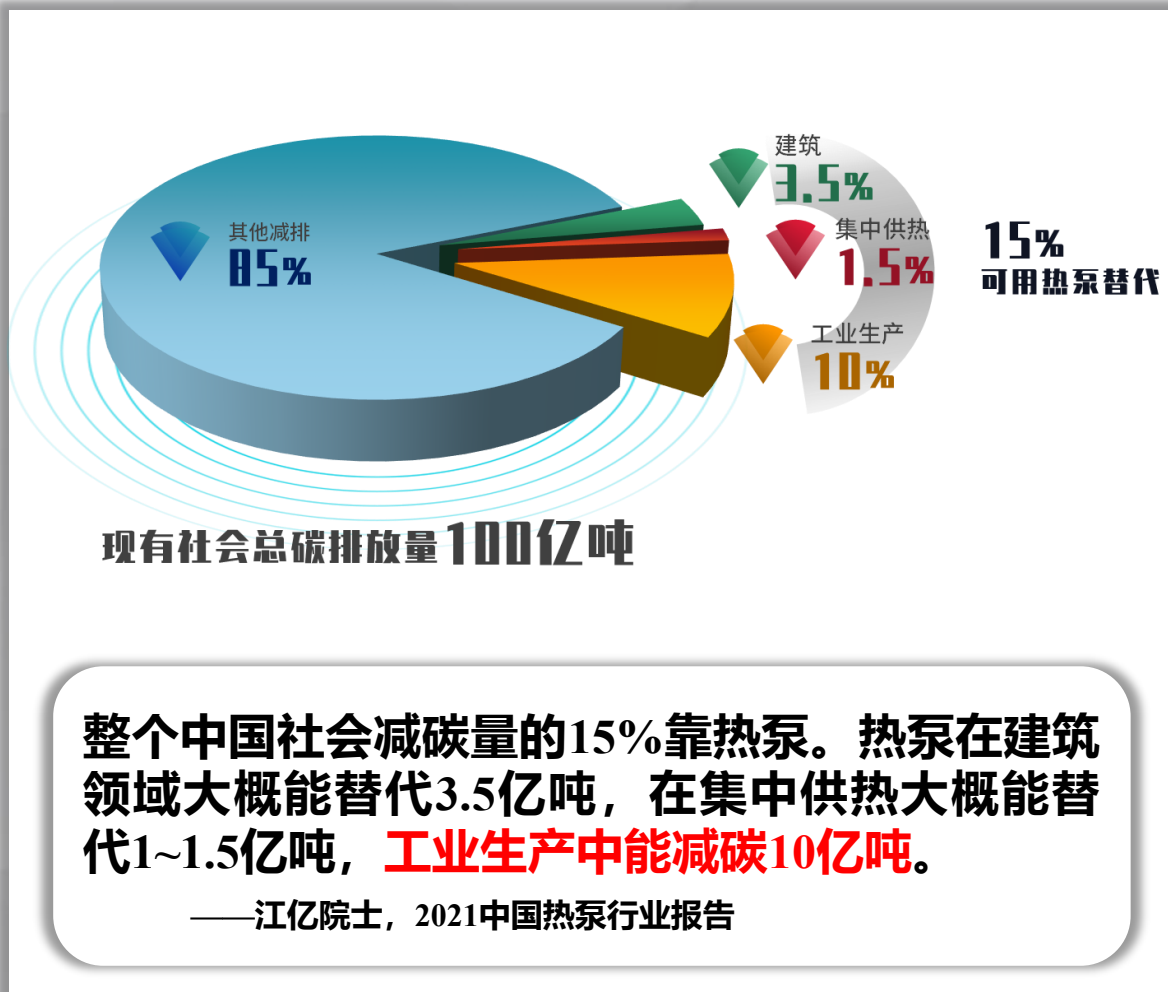

## ? 为什么热泵没有广泛用于工业供热

- 热泵可以吸收来自低品位热源的热能，是更高效经济的电热转换装置
- 但热泵受限于**高温区工质热力性能**，缺乏**系统循环创新**，相关**高温冷却技术**仍需提高



1

背景

2

工业热泵现状与总结

3

工业热泵技术发展路线

4

典型研究案例

5

总结展望



## 工业热泵发展现状

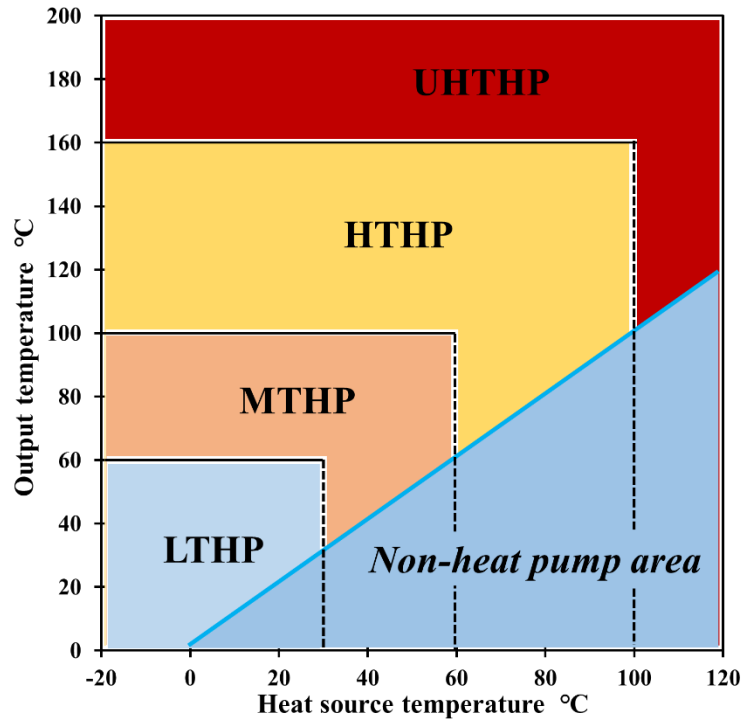

### 热泵温度分区

中、低温热泵技术成熟，已商业化

高温热泵仍处于研究阶段

Sectors	Temperature/°C	20	40	60	80	100	120	140	160	180	200	220 °C
Paper	50-240											
Food & beverages	20-250											
Chemical	20-300											
Automotive	70-130											
Metal	20-200											
Plastic	40-300											
Mechanical engineering	20-120											
Textiles	40-160											
Wood	40-180											
Other sectors	20-110											

Technology readiness level of heat pump:

- LTHPs < 60°C: established in industry;
- MTHPs 60-100°C: commercially available, key technology;
- HTHPs 100-160°C: prototype status, under development;
- UHTHPs 160-200°C: laboratory scale research, functional models, proofs of concept;
- UHTHPs >200°C.



## 国内工业热泵

诺通科技



NT-SP系列蒸汽热泵机组

压缩机型式	双螺杆
最大供热能力	750kW
供热介质	蒸汽
最大供热温度	150°C



## 工业高温热泵应用现状总结

Industry	Use	Configuration	Heat source (in/out) (°C)	Heat sink (in/out) (°C)	Heating capacity *number (kW)	Refrigerant	Compressor	COP	Reference	Year
	Vapor	DS	-	120-160 (steam)	380-660*1	R245fa	Screw	2.5-3.2	Kobe Steel	2011[96]
Distric heating	Heating	DS	40/2	45/88	18,113*5	CFCs/HCs	Centrifugal	3-3.3	Finland	2006 [98]
			15/7	65/90	15,500	-		2.7	Italy	2008 [99]
Oil field	Central heating	SS	45/30	60/75	80*10	R406A	Scroll	3.87	You <i>et al.</i>	2005 [100]
	Crude oil heating	SS	55-65	85-95	675-893*2	R245fa	Twin-screw	3.5-4.4	He <i>et al.</i>	2015 [101]
Food	Winemaking	Cascade	5-35 (ambient)	120 (steam)	150*1	R410A/R245fa	Twin-screw	1.95 (Th=14°C)	Yan <i>et al.</i>	2020 [46]
	Noddle drying	ACHP	99	144.5 (steam)	432*1	NH <sub>3</sub> -H <sub>2</sub> O	-	5.3	Liu <i>et al.</i>	2019 [102]
	Poultry handling, heating,	Cascade	20-30	62-90	270*5	NH <sub>3</sub>	Piston	4.18	Jiang <i>et al.</i>	2019 [103]
SS		83	125	750*1	Water	Twin-screw				
Dyeing	Dyeing liquid	SS	74/64	94.4/97.3	108*1	R245fa	Twin-screw	2.4	Wu <i>et al.</i>	2016 [104]
Drying	Drying	DS+IHX	55/50	70/130	627*1	R134a	Turbo	3	Umezawa <i>et al.</i>	2011 [105]
	Wood drying	SS+DS	43-60	60-95	143*1	R245fa	-	1.42	Zhang <i>et al.</i>	2013 [106]
	Powder making	SS+subcooler, superheater	65/40	75/130	2,250*1	Zeotropic refrigerant	Piston	2.66-3.08 *	Zühlsdorf <i>et al.</i>	2017 [107]
	Spray-drying	ACHP	75/55	85/111(air)	206*1	NH <sub>3</sub> -H <sub>2</sub> O	-	3.5-4.0 *	Jensen <i>et al.</i>	2015 [108]
Medicine	Pharmaceutical	SS+IHX	36.5/31	60/90	1,500-3,900	NH <sub>3</sub>	-	3.0-3.9	Urbanucci <i>et al.</i>	2019 [109]
Chemical industry	-	SS+MVR	58	118(steam)	348*1	R245fa	-	3.05	Lee <i>et al.</i>	2017 [110]

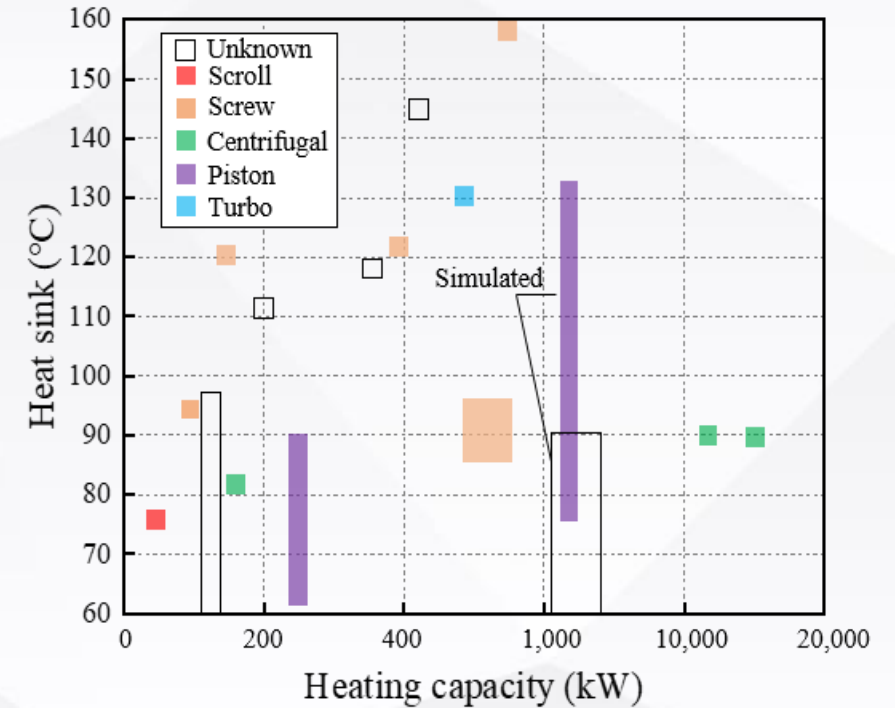

- 单机容量越做越大，大型工业用高温热泵日益增多
- 高温热泵机组工质以R245fa为主，低GWP工质占比小
- 发展大容量高温热泵是扩大热泵在工业领域应用的趋势





## 工业热泵市场现状总结

	10-100kW	100kW-1MW	>1MW
<60°C	Mayekawa Eco Cute Unimo	Kobelco HEM-HR90 Viessmann Vitocal 350-HT Pro Jonson Control Screw、HPX Mitsubishi ETW-L	GREE
60-100°C	Combitherm HWW	Ochsner IWHS ER3 Combitherm HWW Friotherm Unitop 22	Star Neatpump, 三菱 GEA Grasso FXP Johnson Controls Tian OM Friotherm Unitop 50
100-120°C	Mayekawa Eco Sirocco	Ochsner IWDS 330 ER3 Kobelco SGH 120 Durr thermae thermeco2 Hybrid Energy AS	Siemens Energy Man Energy
120-160°C	Viking Heat Booster	Ochsner IWWDS	
160-200°C	Kobelco SGH 165	Hanbell	产品空白

- 目前先进的商用压缩机以日本、欧洲公司为主，我国在压缩机研发制造方面需要投入更多
- 高温(>100°C)离心机目前技术空白，需提高相应冷却技术、开发耐高温润滑油
- 商用的低GWP工质压缩机缺乏



## 工业热泵研究现状总结

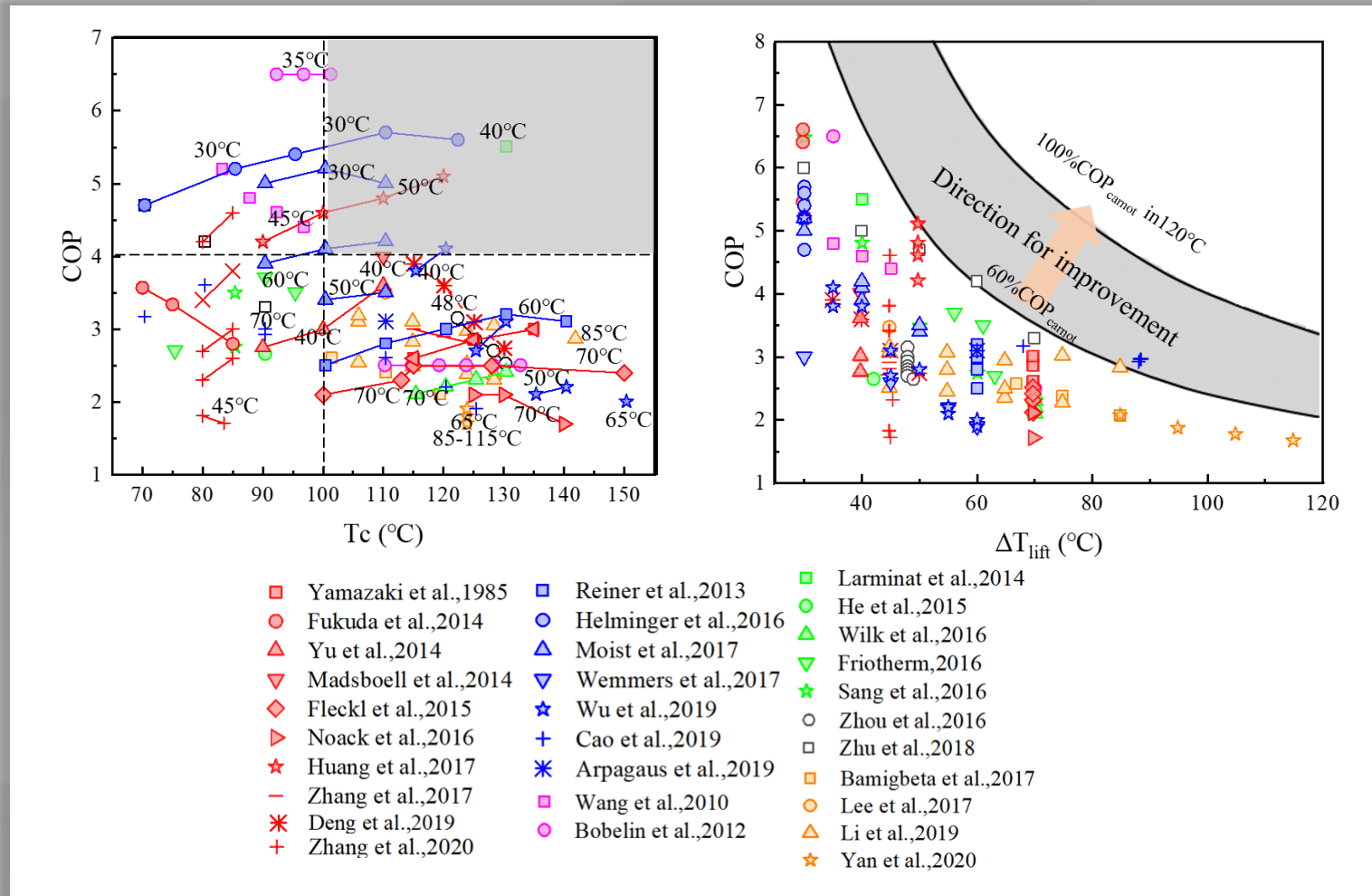

- 温升大于40°C、输出温度高于100°C、COP大于4.0存在空白区域
- 实验室阶段的热泵系统热力完善度在60%以下，因此仍有效率提升空间
- 70%的实验样机以低GWP制冷剂为工质





1

背景

2

工业热泵现状与总结

3

工业热泵技术发展路线

4

典型研究案例

5

总结展望

## 氨余热回收热泵



表 1 出水温度 60 °C ( $T_c=63$ ) 时热泵机组的运行能效

制冷系统冷凝温度/°C	制热量/kW	轴功率/kW	效率 $COP_h$
25	1,307	235	5.6
35	1,709	231	7.4
40	1,935	212	9.1

表 2 出水温度 65 °C ( $T_c=68$ ) 时热泵机组的运行能效

制冷系统冷凝温度/°C	制热量/kW	轴功率/kW	效率 $COP_h$
25	1,286	268	4.8
35	1,671	267	6.3
40	1,914	257	7.4

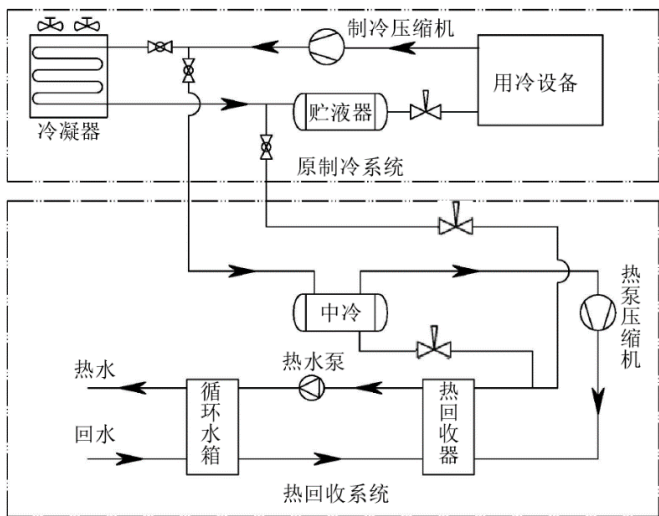
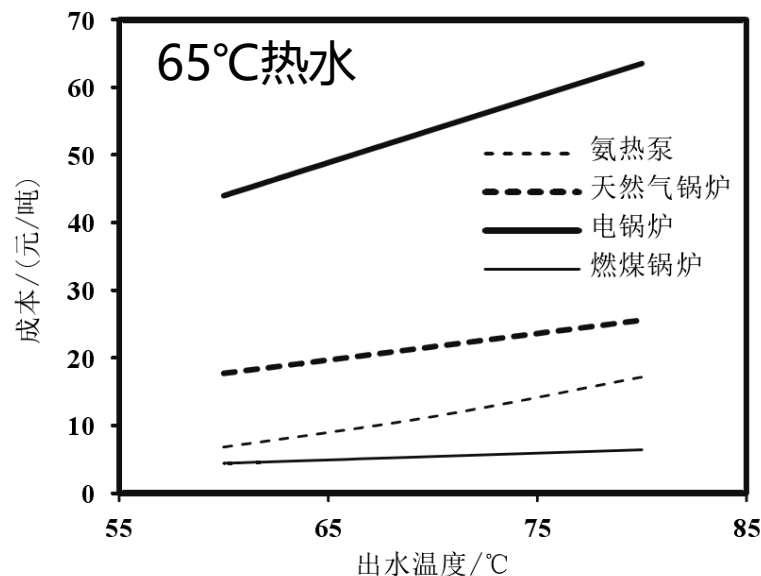

- 该机组可产生40-80°C热水
- 制冷温度-23~2°C
- 夏季工况：-1°C蒸发，51°C冷凝，制冷COP:7.08，制热COP:9.32
- 冬季工况：-1°C蒸发，51°C冷凝，制冷COP:5.33，制热COP:13.88



## CO<sub>2</sub>高温热泵

### 跨临界CO<sub>2</sub>喷射热泵系统

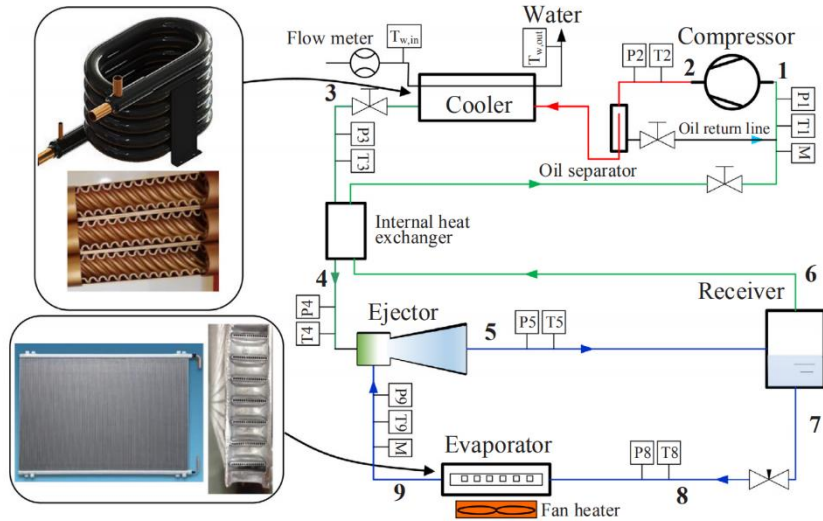

- 该机组可产生最高90°C热水
- 冷凝温度70°C时，系统COP4.6，比传统系统效率提高10.3%
- 采用喷射器更有利于CO<sub>2</sub>应用于高温工况

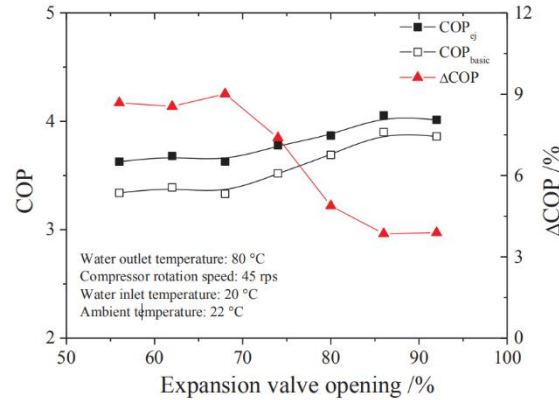

喷射器开度

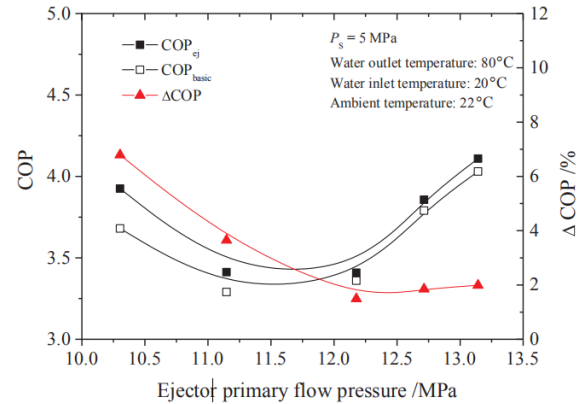

排气压力

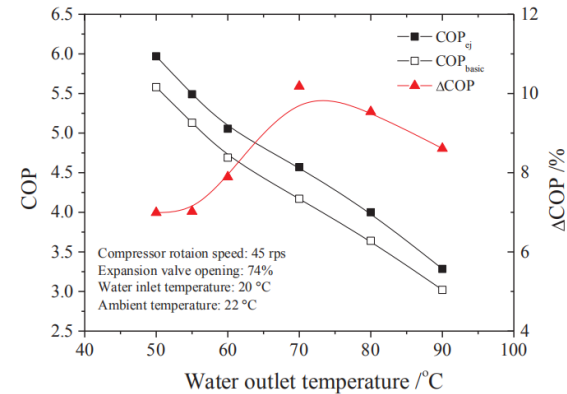

出水温度



# 低GWP工质研究案例



## CO<sub>2</sub>高温热泵

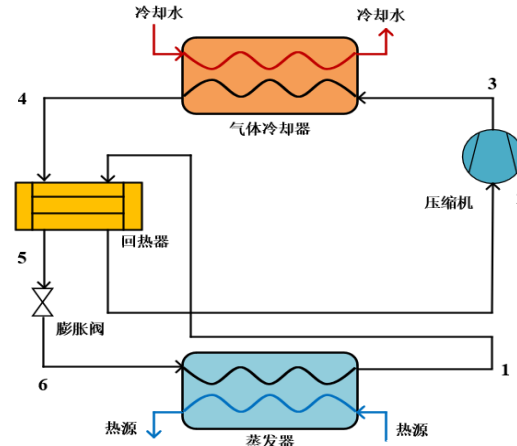
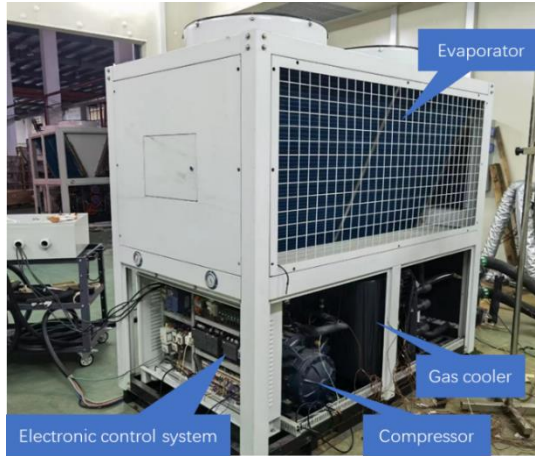

- 当环境温度为40°C，进、出水温度分别为9°C和85°C时，**最大COP为4.47**。
- 本研究在提高出水温度的同时还保证了系统具有较高的COP。对比数据中，**COP最高提升了13%**。

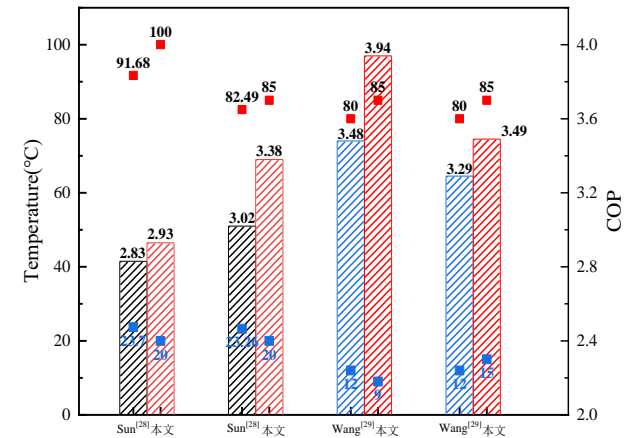
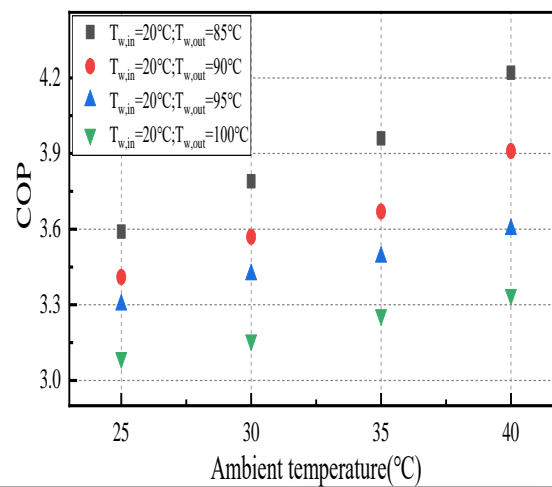
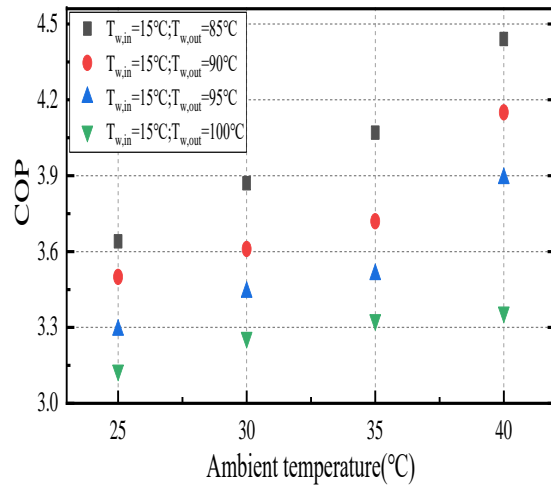
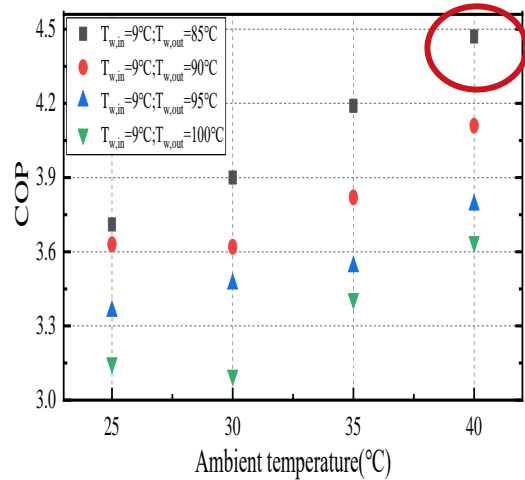



## 水工质高温热泵

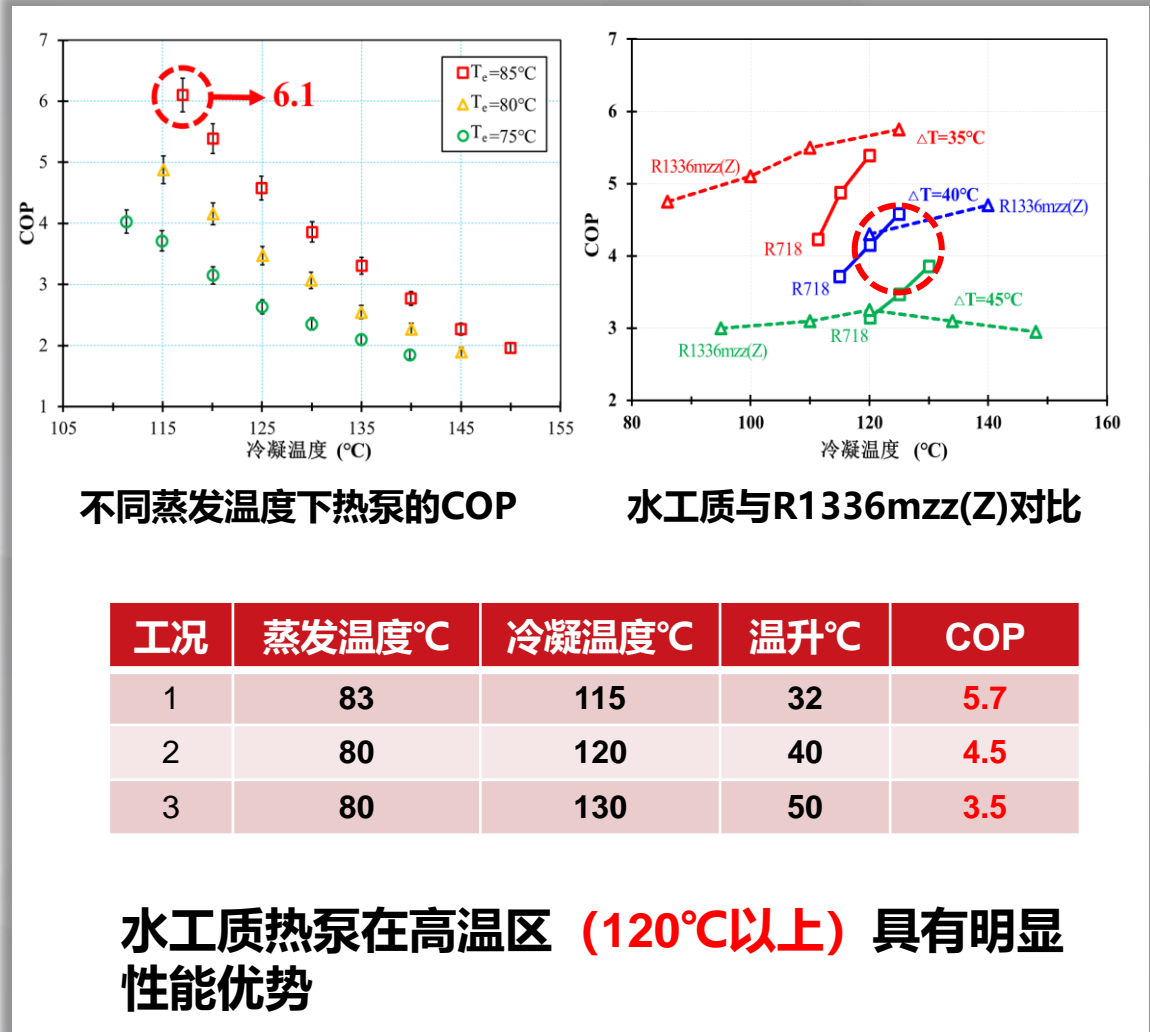
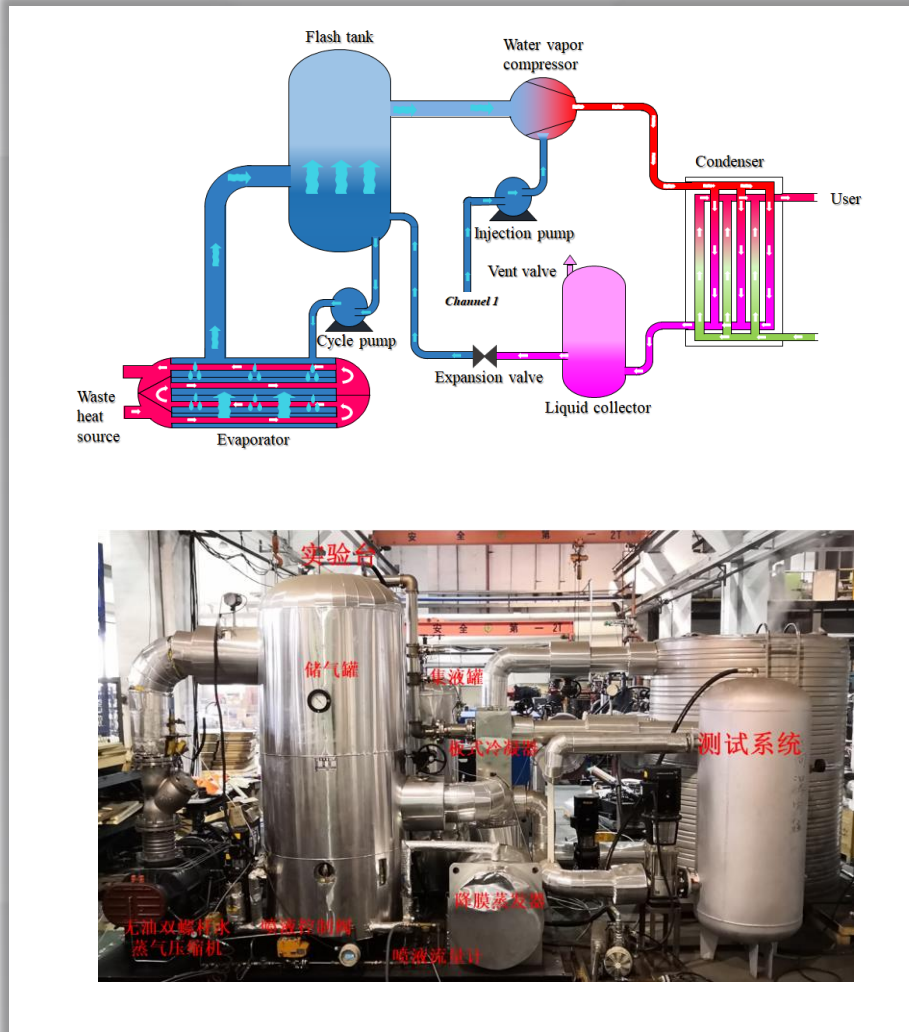



## 大温升蒸汽热泵

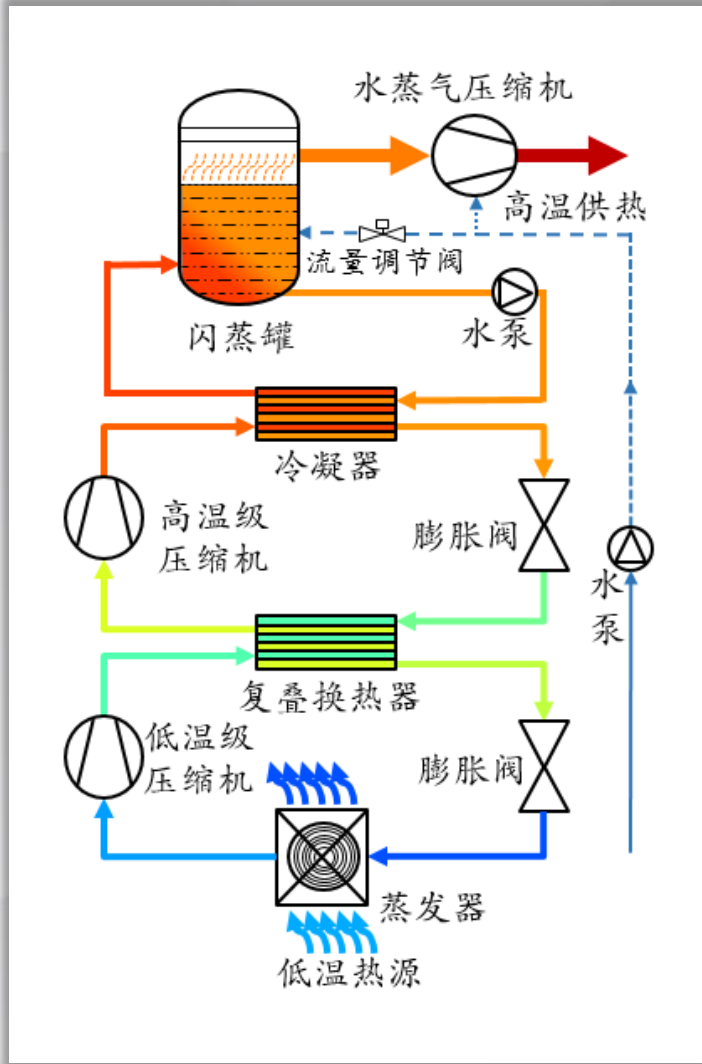

CO<sub>2</sub> Heat pump Water heater:  
Additional for water heating

Flash tank: 3 m<sup>3</sup>

Cascade air source  
Heat pump: 58.5kW\*3

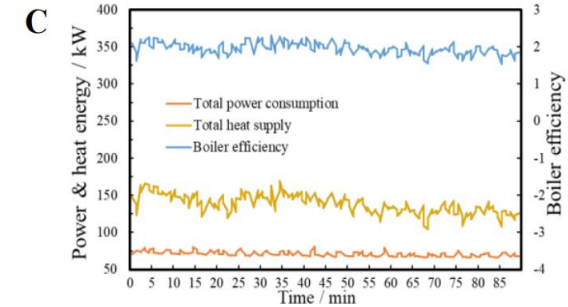
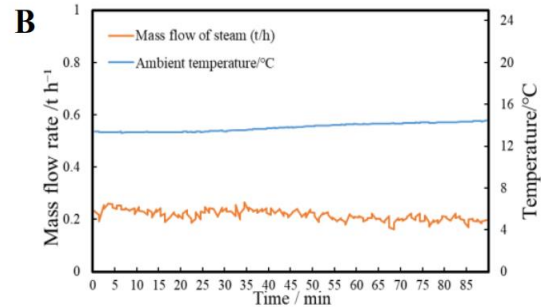

- 每小时可稳定产生0.5吨蒸汽(120°C, 2bar)
- 当室外温度为20°C时, 系统COP为1.95



## ➤ 大温升蒸汽热泵应用案例



### 用户反馈证明

热泵蒸汽系统应用后，使用良好情况，和电蒸汽锅炉相比，使用热泵蒸汽系统后生产效率和提升，据统计，平均节省电量约37%，见下表：

序号	生产日期	电产量 (kg)	电耗量 (kWh)	电耗量 (kWh/kg)	电耗量 (kWh/kg)	节约电量 (%)
1	2020/9/17	723	549	301	41.2%	
2	2020/9/2	908	681	443	34.9%	
3	2020/9/3	884	670	443	34.9%	
4	2020/9/8	924	683	447	35.6%	
5	2020/9/9	870	622	402	34.7%	
6	2020/9/10	843	622	402	35.7%	
7	2020/9/15	863	622	402	35.7%	
8	2020/9/16	843	622	402	35.7%	
9	2020/9/17	607	456	439	37.8%	
10	2020/9/18	924	593	293	35.8%	
11	2020/9/22	934	700	402	41.3%	
12	2020/9/24	926	702	471	33.0%	
13	2020/9/25	845	710	466	34.5%	
14	平均值	869	652	412	37.0%	

节能效果显著，值得推广。

生产负责人 (盖章) \_\_\_\_\_  
生产单位 (盖章) \_\_\_\_\_  
2020年11月17日



- 原有电锅炉耗电652kWh，蒸汽热泵耗电量412kWh，节约电量37%，相比原电锅炉系统节能近40%，预计每年节省近65万元，三年内回收投资成本

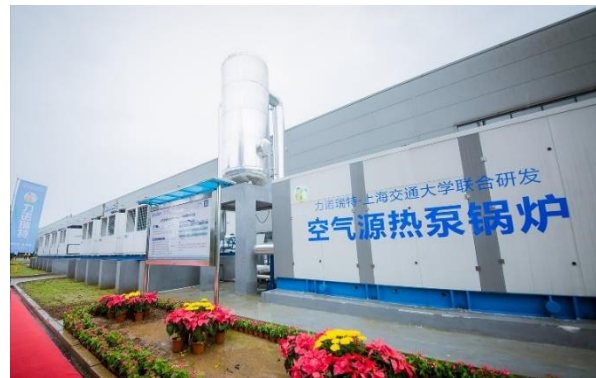

- ✓ 项目地点：中药饮片工厂
- ✓ 设计容量：1t/h
- ✓ 使用压力：0.4Mpa
- ✓ 使用温度：150℃
- ✓ 系统COP：1.6

- 原来从电厂购买蒸汽380元/吨，蒸汽热泵蒸汽270元/吨，每年预计节省近66万元，预计四年回收投资成本





## 烷烃复叠热泵

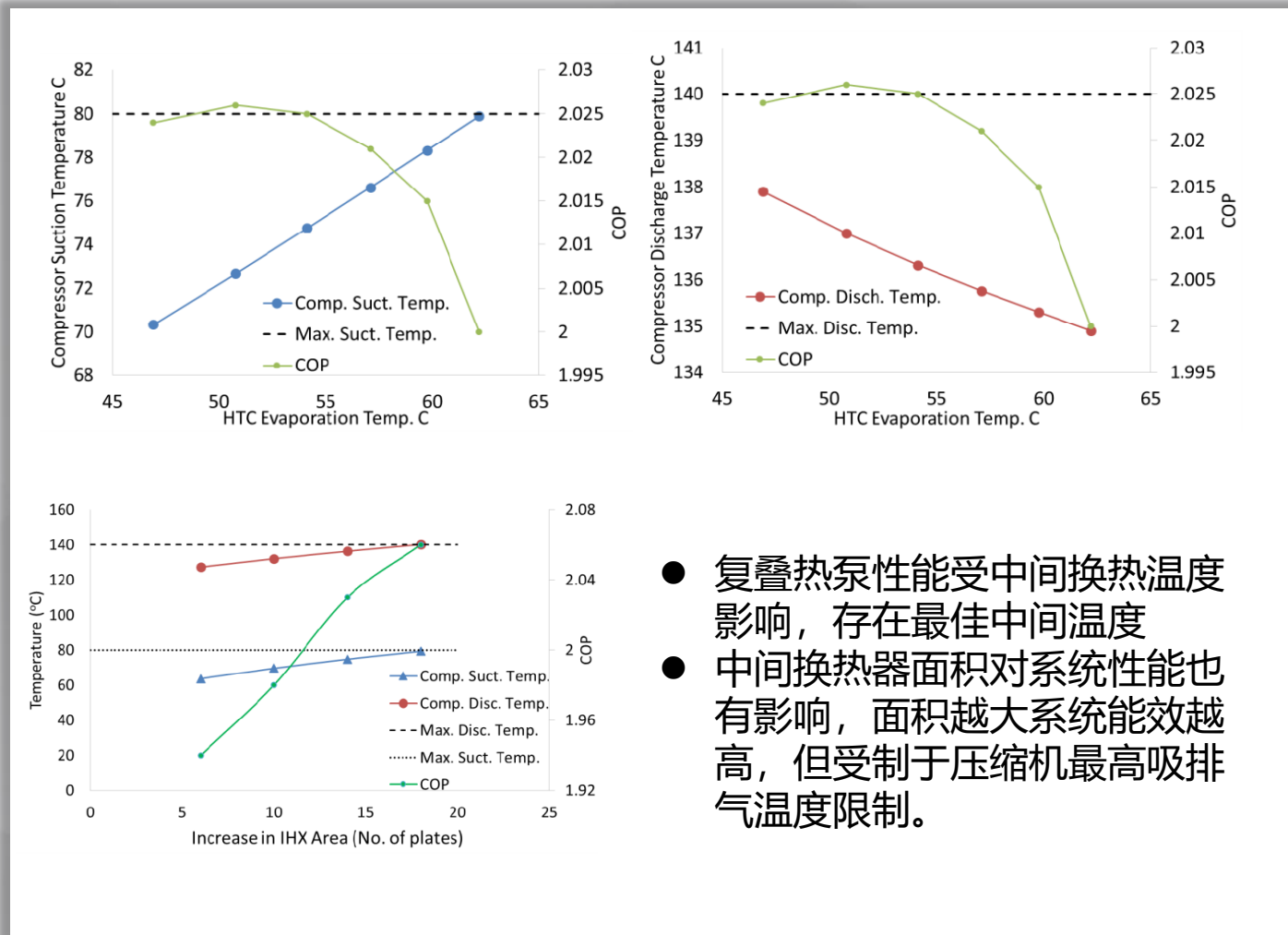
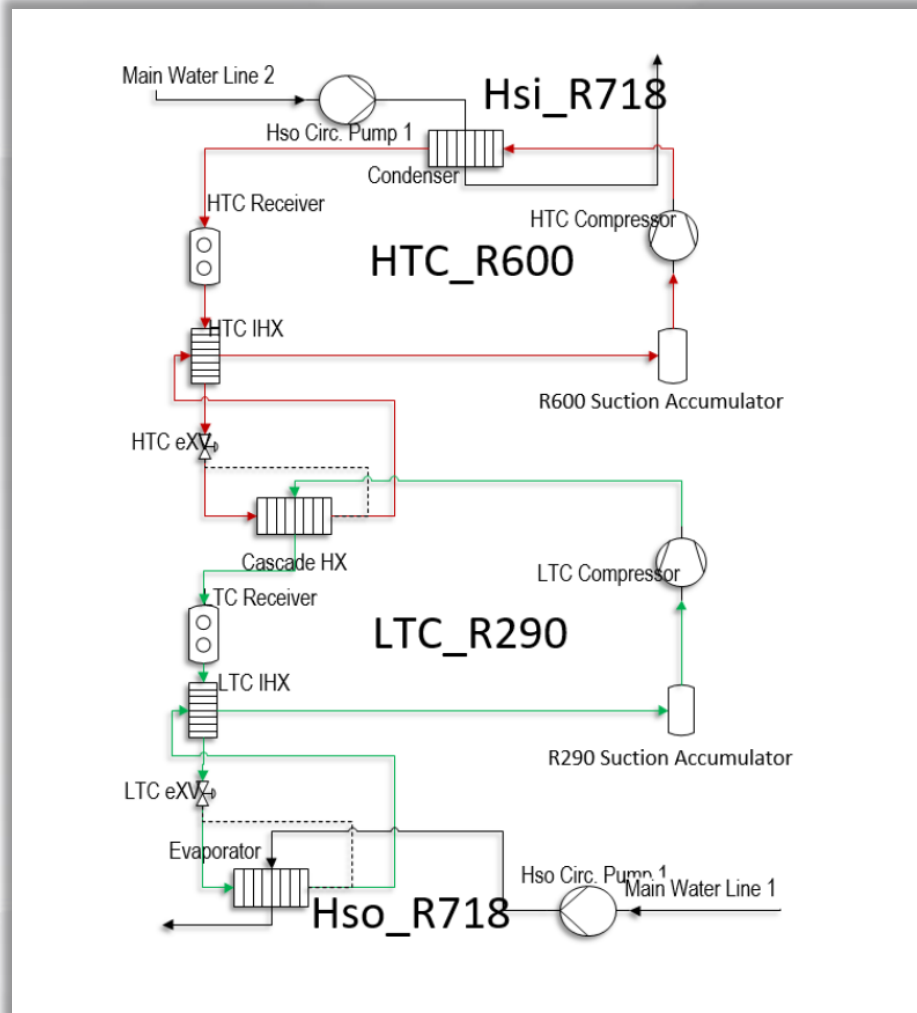

- 复叠热泵性能受中间换热温度影响，存在最佳中间温度
- 中间换热器面积对系统性能也有影响，面积越大系统能效越高，但受制于压缩机最高吸排气温度限制。





## ➤ R1233zd(E)

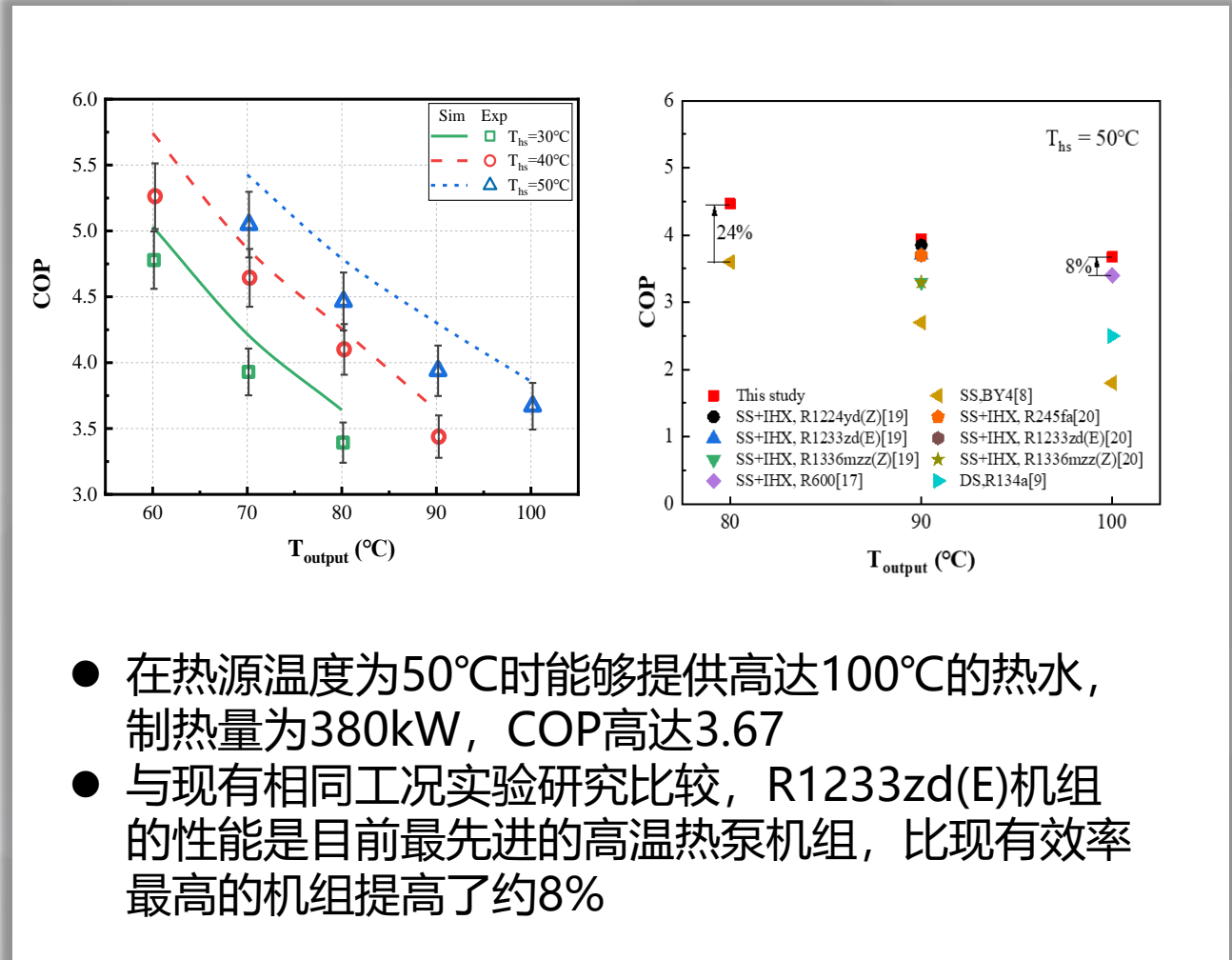
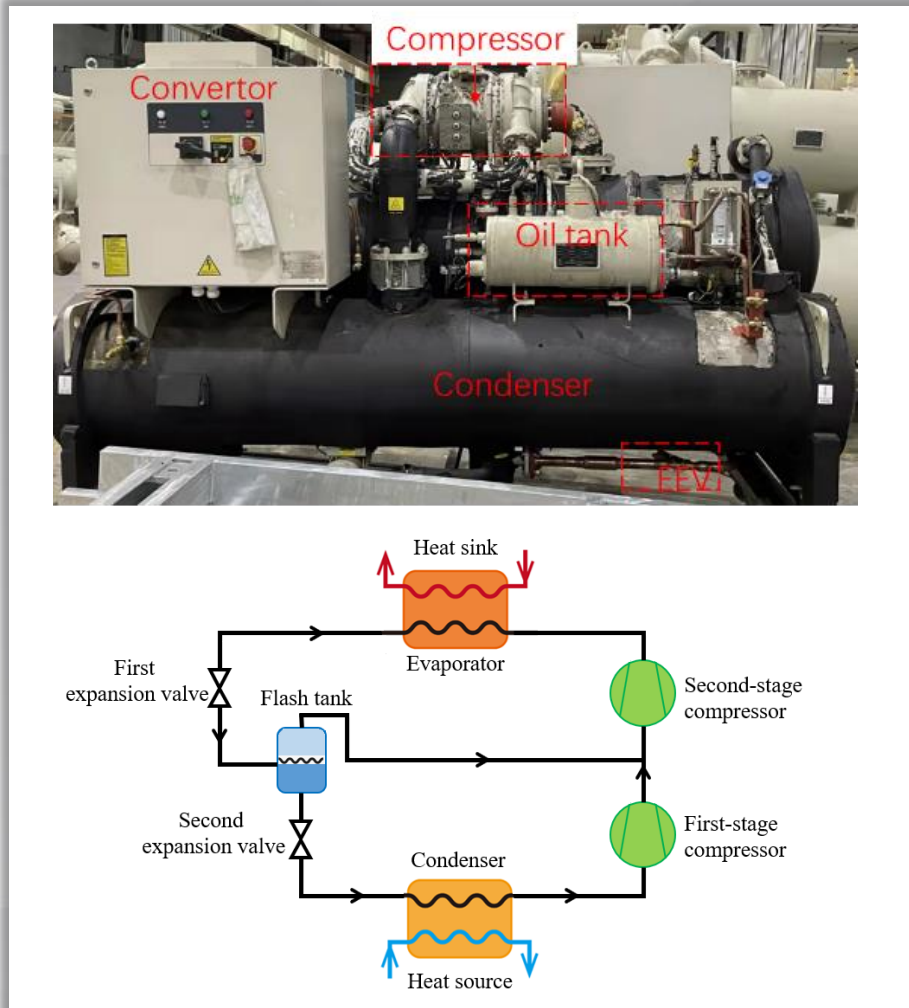

- 在热源温度为50°C时能够提供高达100°C的热水，制热量为380kW，COP高达3.67
- 与现有相同工况实验研究比较，R1233zd(E)机组的性能是目前最先进的高温热泵机组，比现有效率最高的机组提高了约8%





# 低GWP工质研究案例



## ➤ R1336mzz

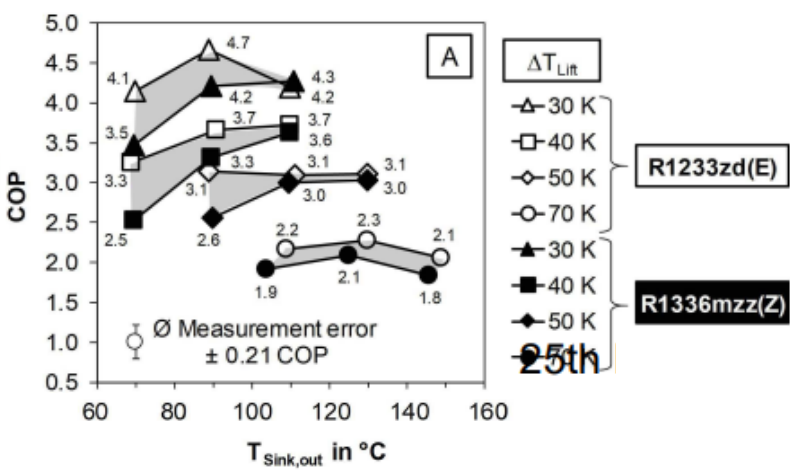
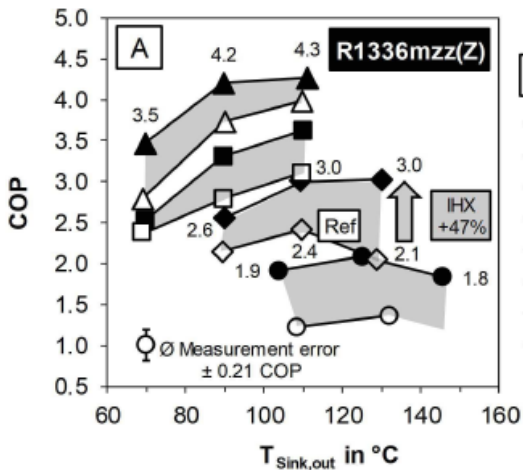
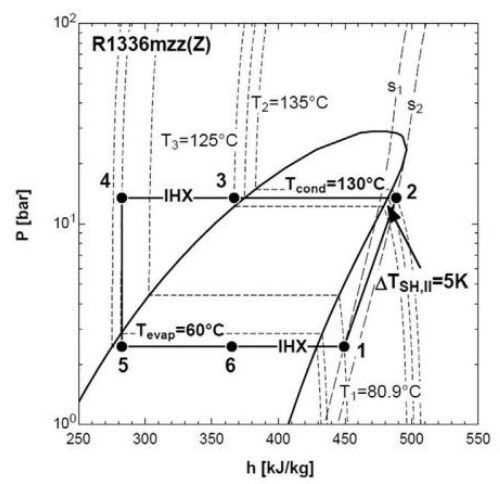
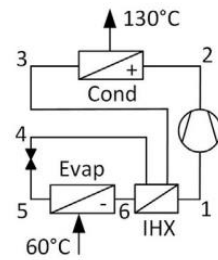
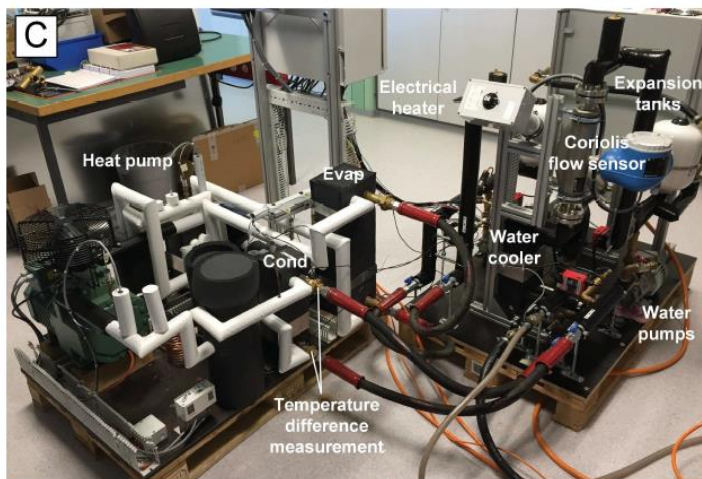
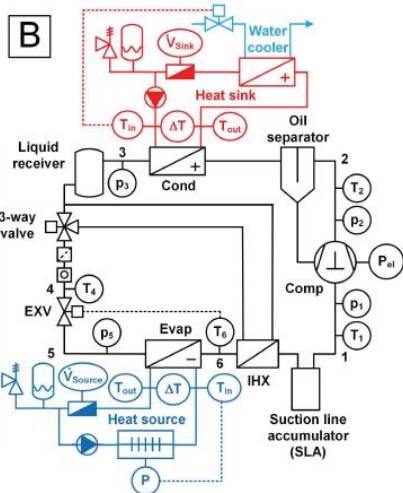
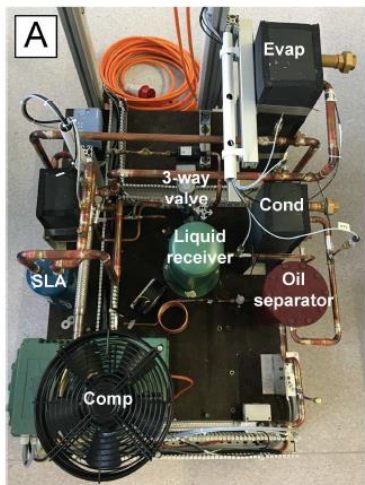

- R1336mzz临界温度更高(171.3°C)
- 带IHX的单级压缩系统测试中, R1233zd(E)比R1336mzz性能更好
- 由于R1336mzz的等熵压缩线斜率的特殊性, 可能出现压缩机出口的湿压缩, 因此需要提高压缩机入口的过热度, 增加回热器





## ➤ R1234ze

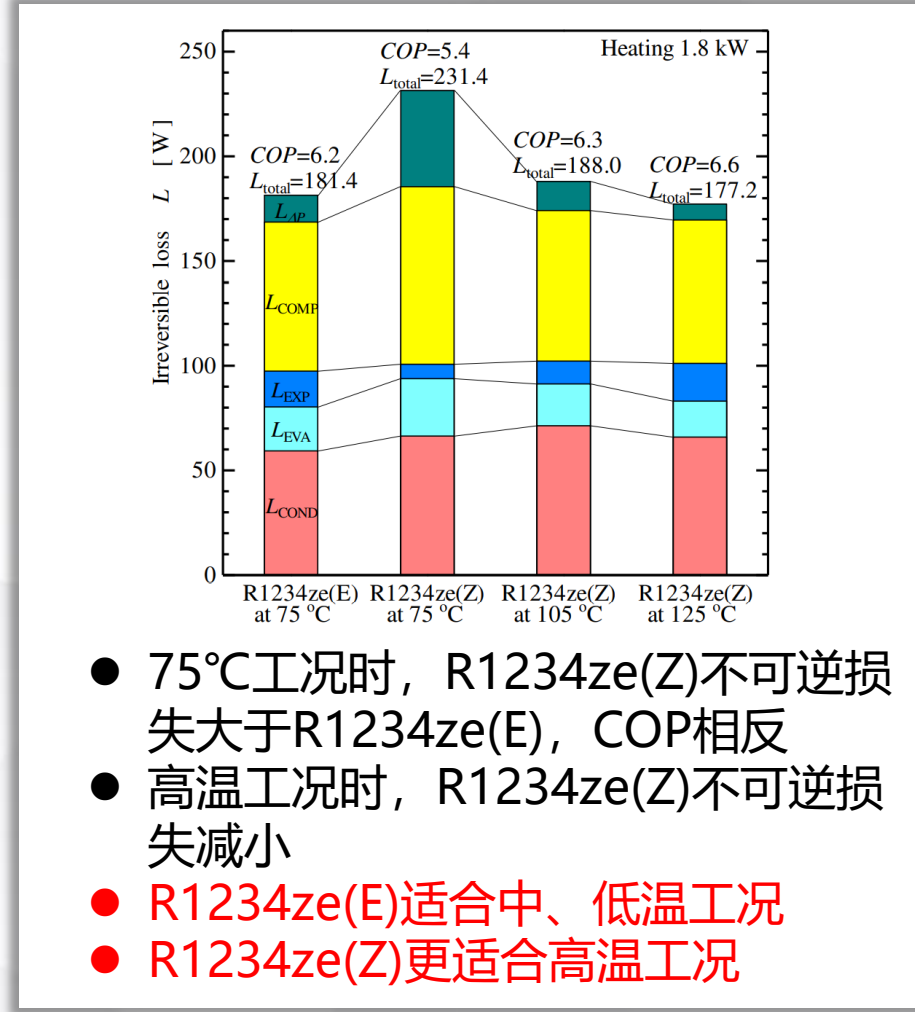
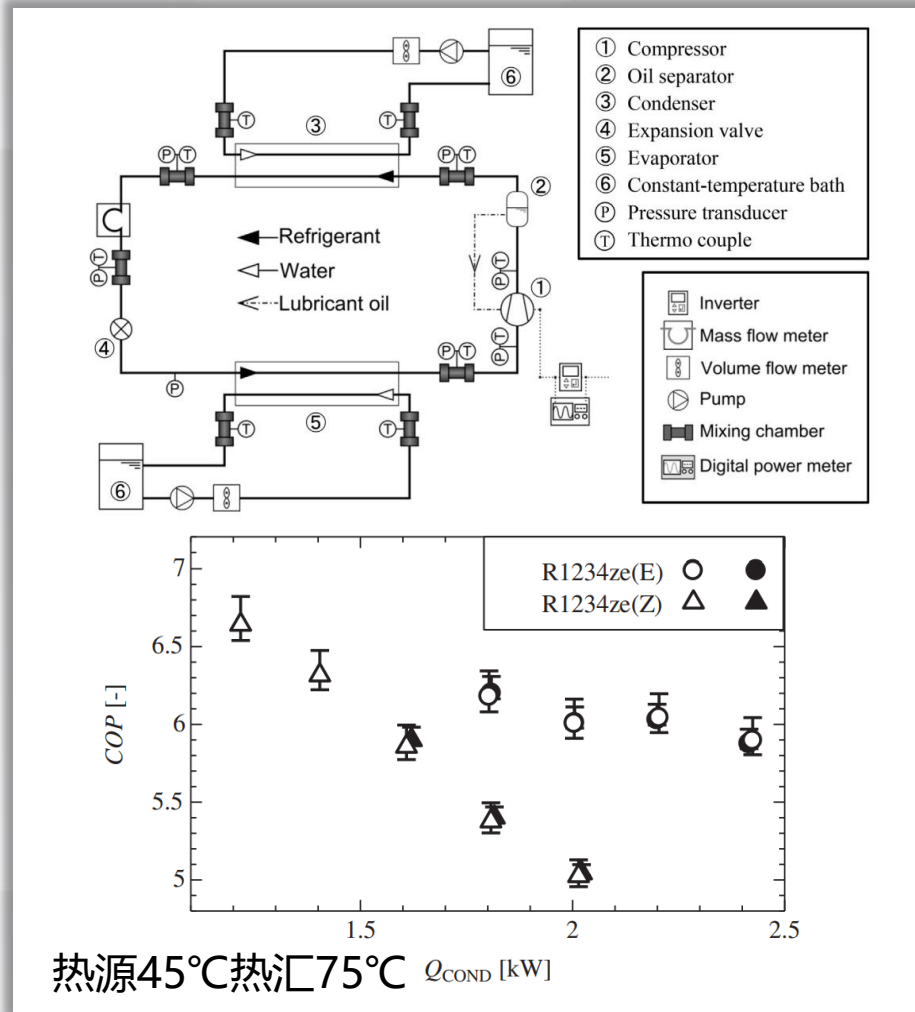

- 75°C工况时, R1234ze(Z)不可逆损失大于R1234ze(E), COP相反
- 高温工况时, R1234ze(Z)不可逆损失减小
- R1234ze(E)适合中、低温工况
- R1234ze(Z)更适合高温工况





## ➤ HP-1

采用新型环保冷媒HP-1，研发**输出温度大于110度的螺杆式工业热泵**，回收50-60度的低温余热，可直接输出蒸汽，并结合水蒸气压缩机，满足标注工业蒸汽的需求。

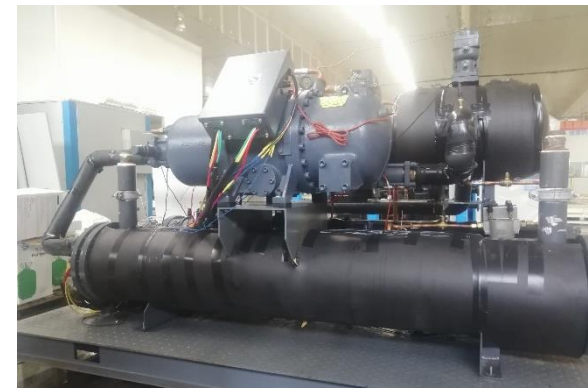
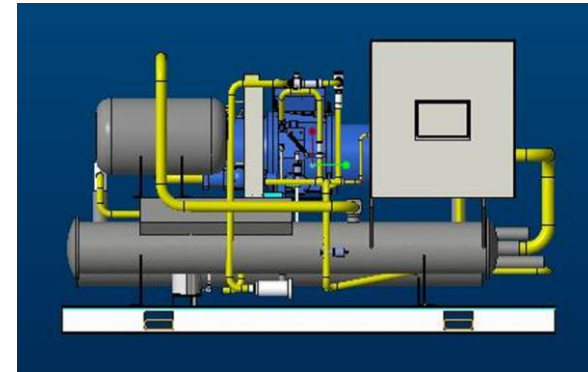
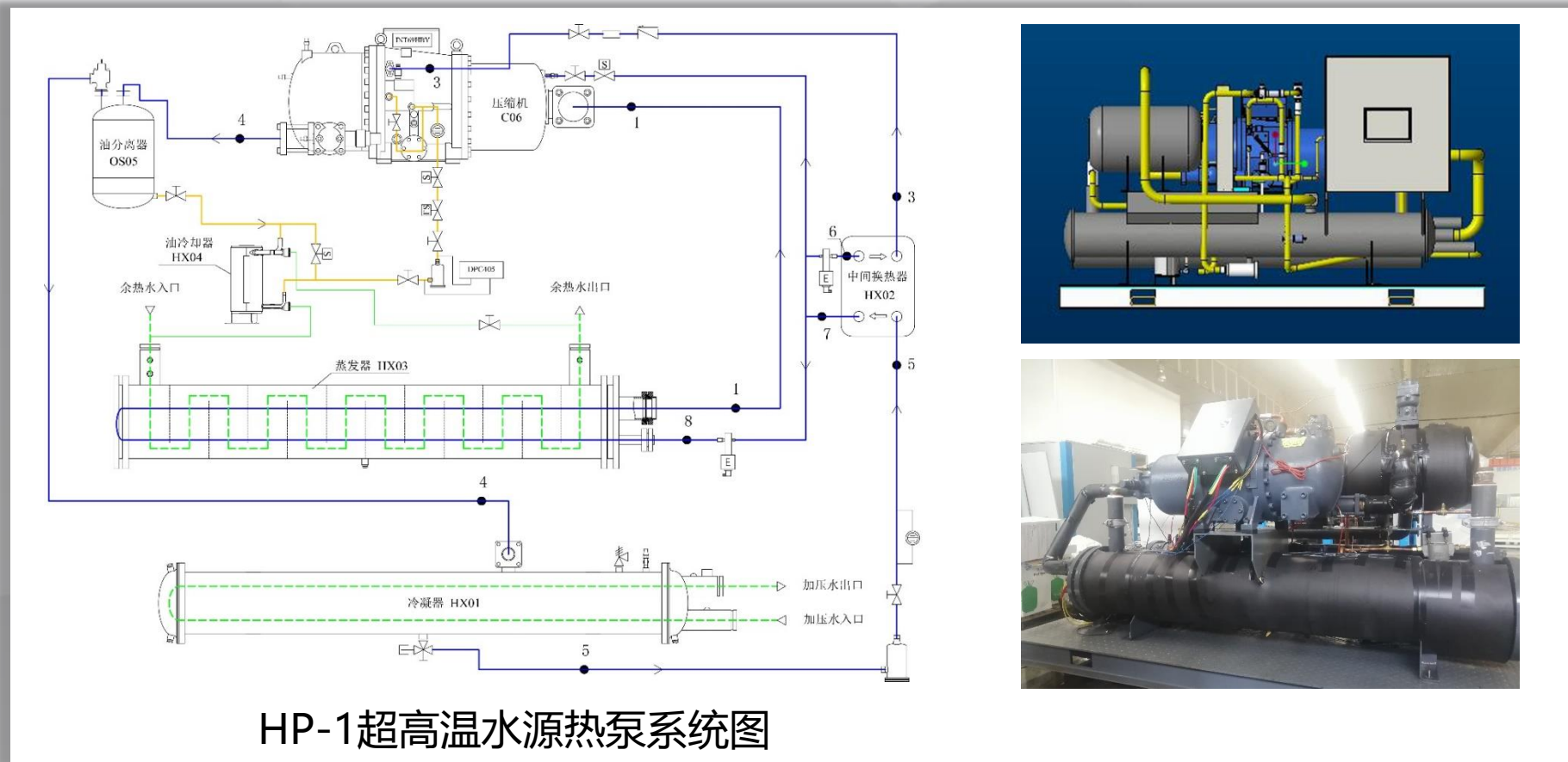



# 低GWP工质研究案例



## ➤ NBY-1

膨胀阀开度(p)	制热温度(°C)	制热量(kW)	输入功率(kW)	COP-	压缩比-	冷凝压力(MPa)	排气温度(°C)
210p	115.3	17.29	4.41	3.92	3.99	1.98	123.4
	120.0	16.73	4.67	3.58	4.07	2.12	126.4
	125.0	15.80	5.02	3.15	4.31	2.30	130.4
	130.4	15.36	5.59	2.75	4.74	2.55	136.2

### 实验条件:

- 蒸发器进水温度 80°C      工质充注量 3.3kg
- 蒸发器侧水流量 2.4m³/h      冷凝器侧水流量 2.6m³/h

## BY-5与NBY-1热泵循环性能参数对比

工质	Q <sub>c</sub> (kW)			P <sub>in</sub> (kW)			COP		
	120°C	125°C	130°C	120°C	125°C	130°C	120°C	125°C	130°C
BY-5	14.91	14.62	13.66	4.96	5.38	5.97	3.00	2.72	2.25
NBY-1	15.82	14.93	14.33	4.76	5.19	5.58	3.32	2.87	2.57
提升率 %	6.10	2.12	4.90	-4.03	-3.53	-6.53	10.67	5.51	14.22

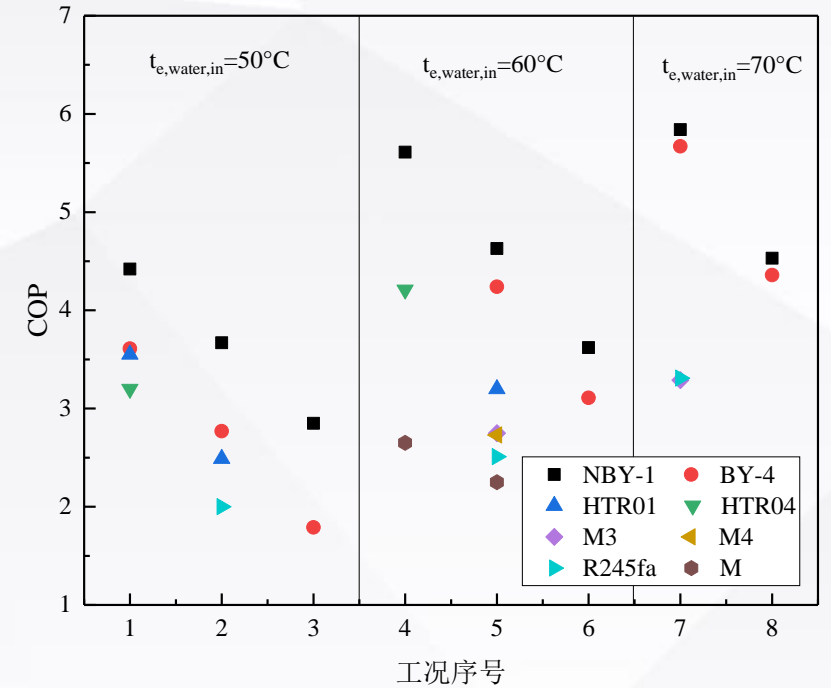



1

背景

2

工业热泵现状与总结

3

工业热泵技术发展路线

4

典型研究案例

5

总结展望



## ➤ 热泵推荐低GWP工质

	低温热泵	中温热泵	高温热泵		超高温热泵
温区	<60℃	60-100℃	100-120℃	120-160℃	160-200℃
工质	R290 R1270 R1234yf R717 R744	R717,R744 R152a R161 R600a R1234ze(E)	R600 R1234ze(Z) R1224yd(Z)	R601 R1336mzz(Z) R1233zd(E) R718	R718
压缩机	活塞机、螺杆机				<100kW
	螺杆机、活塞机、离心机		螺杆机、离心机		100kW-1MW
	螺杆机、离心机		离心机		>1MW

## ➤ 大温升热泵推荐低GWP工质

	低温	高温	低温	高温	低温	高温
温区/℃	-20~0	80~100	0~20	100~120	20~60	130~160
推荐制冷剂	R717 R744	R717,R744 R161,R152a, R600a, R1234ze(E)	R290 R717 R744	R600 R1234ze(Z) R1224yd(Z)	R290, R717, R744, R1270, R1234yf	R601 R1336mzz(Z) R1233zd(E) R718
压缩机	螺杆、活塞	螺杆、离心	螺杆、活塞、 涡旋	螺杆、离心	螺杆、活塞	螺杆、离心

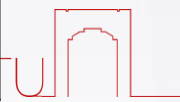



## ➤ 工业高温热泵研发展望

1、高温热泵机组(供热温度 $>120^{\circ}\text{C}$ )

2、跨临界 $\text{CO}_2$ 热泵机组(供热温度 $>100^{\circ}\text{C}$ )

3、高温涡旋/活塞冷媒压缩机主机(供热温度 $>100^{\circ}\text{C}$ )

4、双螺杆蒸汽压缩机主机(供热温度 $>120^{\circ}\text{C}$ )



**谢谢！  
敬请批评指正！**

**吴迪**

**上海诺通新能源科技有限公司 / 上海交通大学**

饮水思源 爱国荣校